



VERTICAL AND HORIZONTAL BLADDER TANKS

Data and specification sheet DS-MXC rev. 0

APPLICATION

The Viking bladder tank, together with Viking ratio controllers, form a balanced pressure proportioning system used to mix water and fire fighting foam together to generate an effective extinguishing medium.

The bladder tank technology is a reliable and precise mixing method that is widespread in the fire fighting industry. This method allows the water/foam ratio to remain stable by automatically adjusting to the variable flow rates and pressure conditions that may occur during system operation.

This feature makes bladder tanks particularly suitable for multiple hazard systems, sprinkler systems and any other system operating under variable, non predictable, flow and pressure conditions.

FUNCTIONAL DESCRIPTION

The Viking bladder tank is a carbon steel pressure vessel (stainless steel construction optional) containing an elastomeric separation bladder between the water and foam concentrate. The bladder permits water pressure to be transferred to the foam concentrate without the two fluids mixing together. A Viking ratio controller, as described in a separate data sheet, generates a water pressure drop by means of a reduced cross section where the water stream passes through it. As the foam concentrate pressure is higher than the pressure at the ratio controller, the foam starts flowing towards the water and mixing at a calibrated rate, which is dependant on the water flow rate.

APPROVALS

- **FM approved** (vertical & horizontal tanks, all the sizes) (FM versions subject to extra price in respect to standard versions)
- **CE marked** according to the **PED Directive 97/23/EC** (1000 litres capacity of larger). For smaller sizes Viking bladder tanks are 97/23/EC compliant even if CE mark is not applicable
- **CE marked** according to **ATEX Directive 94/9/CE** where required
- **Fire Safety Certified** for Russian Federation territory
- Viking ratio controllers (standard and wide range) for bladder tanks are FM approved too. Please refer to the applicable data sheets to find out the approval types.

CONSTRUCTION FEATURES

- Vertical type on legs or horizontal type on saddles. Legs and saddles are provided with fixing holes
- Supplied either with pre-piped/pre-trimmed ratio controllers or with loose ones
- Manufactured according to ASME Sec. VIII Div. 1, EN13445 or ISPEL-VSR codes at Customer's choice
- Design pressure 175 psi (12.1 bar)
- 100% pressure tested according to the applied design code but not less than 251 psi (17.3 bar)
- Shell and heads in ASTM A516 Gr. 70 or EN10028-3 P275NH/P355NH
- A106 Gr. B water and foam piping (stainless steel as an option)
- Machine welded circumferential and longitudinal seams for maximum quality and durability
- Welded lifting lugs for easy handling operations
- Earth lug
- Thermal relief valve provided on the water side



- Bladder in polyester reinforced hypalon-neoprene polymers, with an ASTM D-412 Tensile Strength of at least 6500 psi to ensure no ruptures under operation condition
- Bladder equipped with cast rubber caps to ensure water and foam tightness under constantly pressurized conditions
- Bladder tanks are oversized to permit concentrate thermal expansion (volume expansion allowance)
- Tank equipped with drain/fill/vent valves needed for full operation, made in corrosion resistant nickel covered brass
- Tank equipped with inside protection at any opening to ensure no damage to the bladder
- Internal PVC foam distribution pipe (one pipe for the vertical type, two orthogonal pipes for the horizontal)
- Internal water distribution pipe to equalize the water pressure everywhere avoiding damage to the bladder and to drain the tank under any condition
- Nameplate in corrosion resistant material
- Nameplate holder to avoid undetected corrosion on the tank's shell behind the plate
- Analog level indicator instead of classic sight glasses to avoid foam soiling or foam leakage in case of ruptures
- External epoxy zinc rich primer/aliphatic polyurethane finish tested by FM for corrosive atmosphere

OPTIONS

- FM approved Concentrate Control Valve
- Automatic water control valve
- Mixing ratio selector 0%-6%
- Internal epoxy protective layer (recommended for salt-water applications) or external harsh-environment cycle
- Higher wall thickness for corrosion allowance
- Higher pressure ratings, seismic rating
- Ladders, work platforms, sunshade
- Classic style sight glass level indicator
- Water and foam piping in stainless steel AISI316 grade
- Full bladder tank stainless steel construction
- Manual or electrical filling pump
- Heat tracing and/or insulation
- Foam flow-meter and mixing ratio measuring circuit (water-on-water measuring procedure to avoid foam discharge)
- Bladder tank and ratio controllers pre-assembled on skid or installed in container



VERTICAL AND HORIZONTAL BLADDER TANKS

Data and specification sheet

DS-MXC rev. 0

STANDARD MATERIALS

Tank shell	: ASTM A516 Gr. 70 or : P275NH to EN10028-3 or : P355NH to EN10028-3
Bladder	: Polyester reinforced : hypalon-neoprene polymers
Trim valves	: Nickel coated brass
Thermal Relief Valve	: Brass
Pressure Gauges	: Stainless steel
Level Indicator	: Stainless steel
Water and Foam Pipes	: ASTM A106 Gr. B
Flanges	: ASTM A105

STANDARD DESIGN DATA

Design Pressure	: 175 psi (12.1 bar)
Test Pressure	: ≥ 251 psi (17.3 bar)
Design Metal Temp.	: -10°C; +50°C
Capacity	: see tables
Empty Weight	: see tables
Mixing Range	: see ratio controller data sheet

(*) *Temperature limitations normally come from foam concentrate and water*

ORDERING INFORMATION

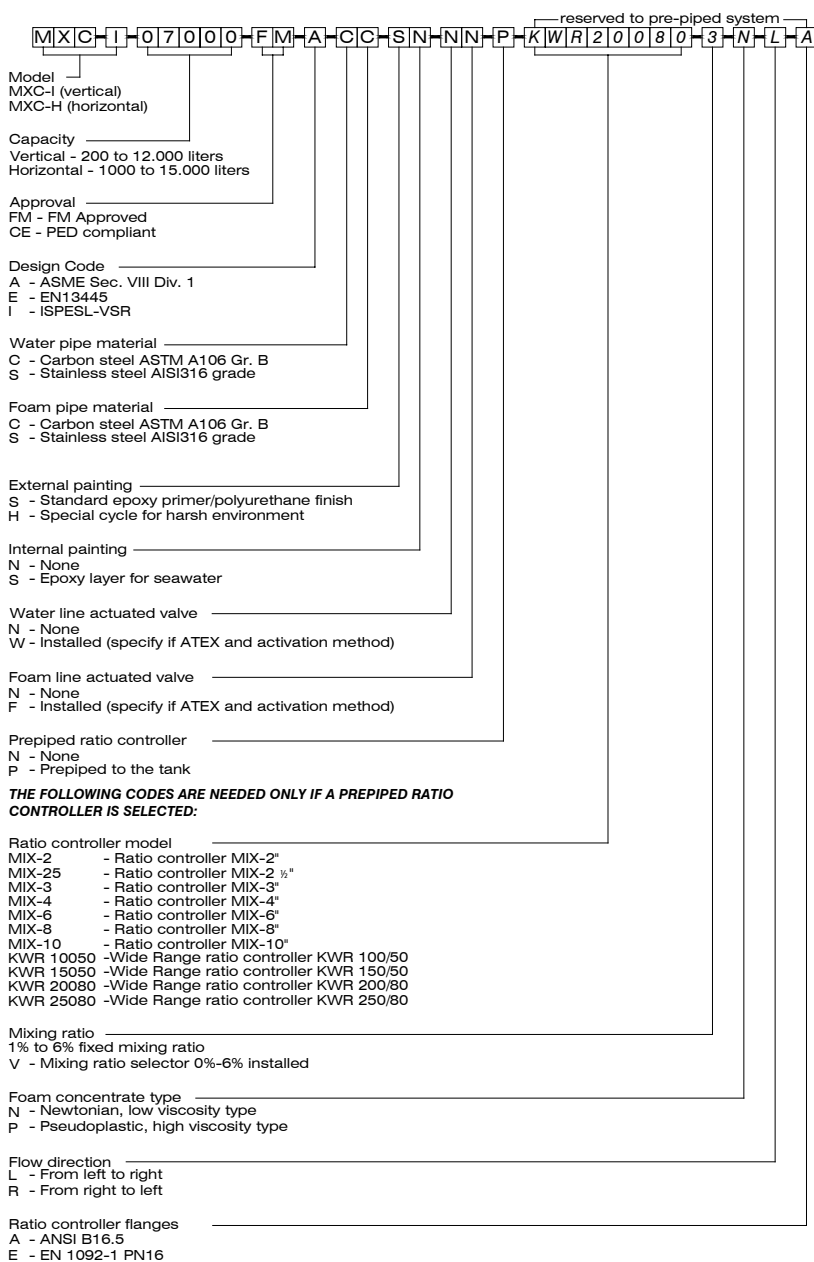

Note: some of the available options may be not covered by the FM approval. Please always make reference to the approval details or ask Viking.



VERTICAL AND HORIZONTAL BLADDER TANKS

Data and specification sheet DS-MXC rev. 0

VERTICAL BLADDER TANKS WITHOUT RATIO CONTROLLER

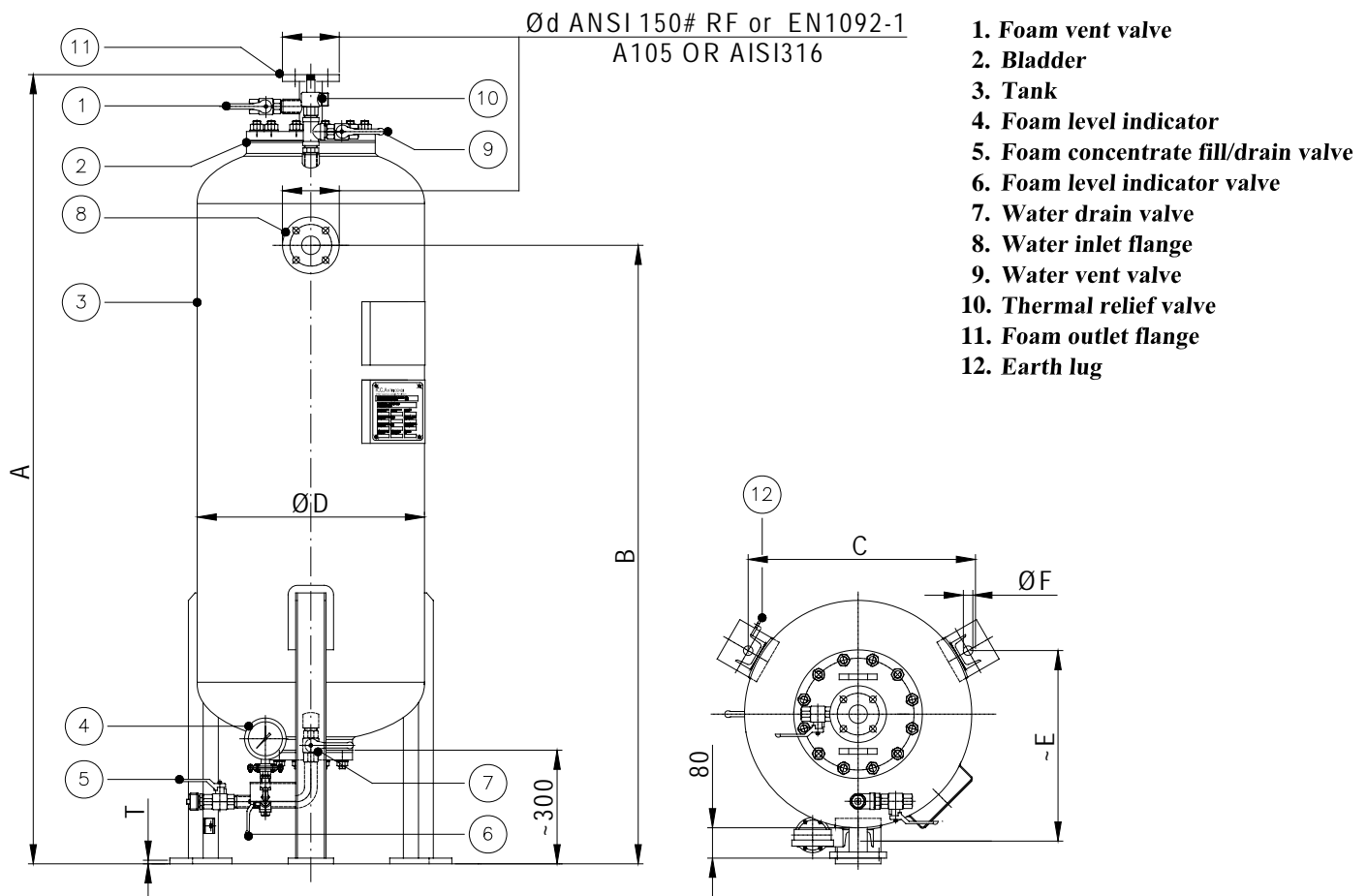

CAPACITY litres	Ød	A mm	B mm	C mm	ØD mm	E mm	T mm	ØF mm	WEIGHT (Kg)
200	2"	1550	1100	581	600	503	15	18	150
400	2"	2100	1650	581	600	503	15	18	170
600	2"	2000	1450	756	800	655	15	18	200

(* The weight shown refers to the ISPESEL-VSR version, design pressure 175 psi (12,1 barg)

All the dimensions are in mm

Note: some of the available options may be not covered by the FM approval. Please always make reference to the approval details or ask Viking.



**VERTICAL AND HORIZONTAL
BLADDER TANKS**
Data and specification sheet DS-MXC rev. 0

VERTICAL BLADDER TANKS WITHOUT RATIO CONTROLLER

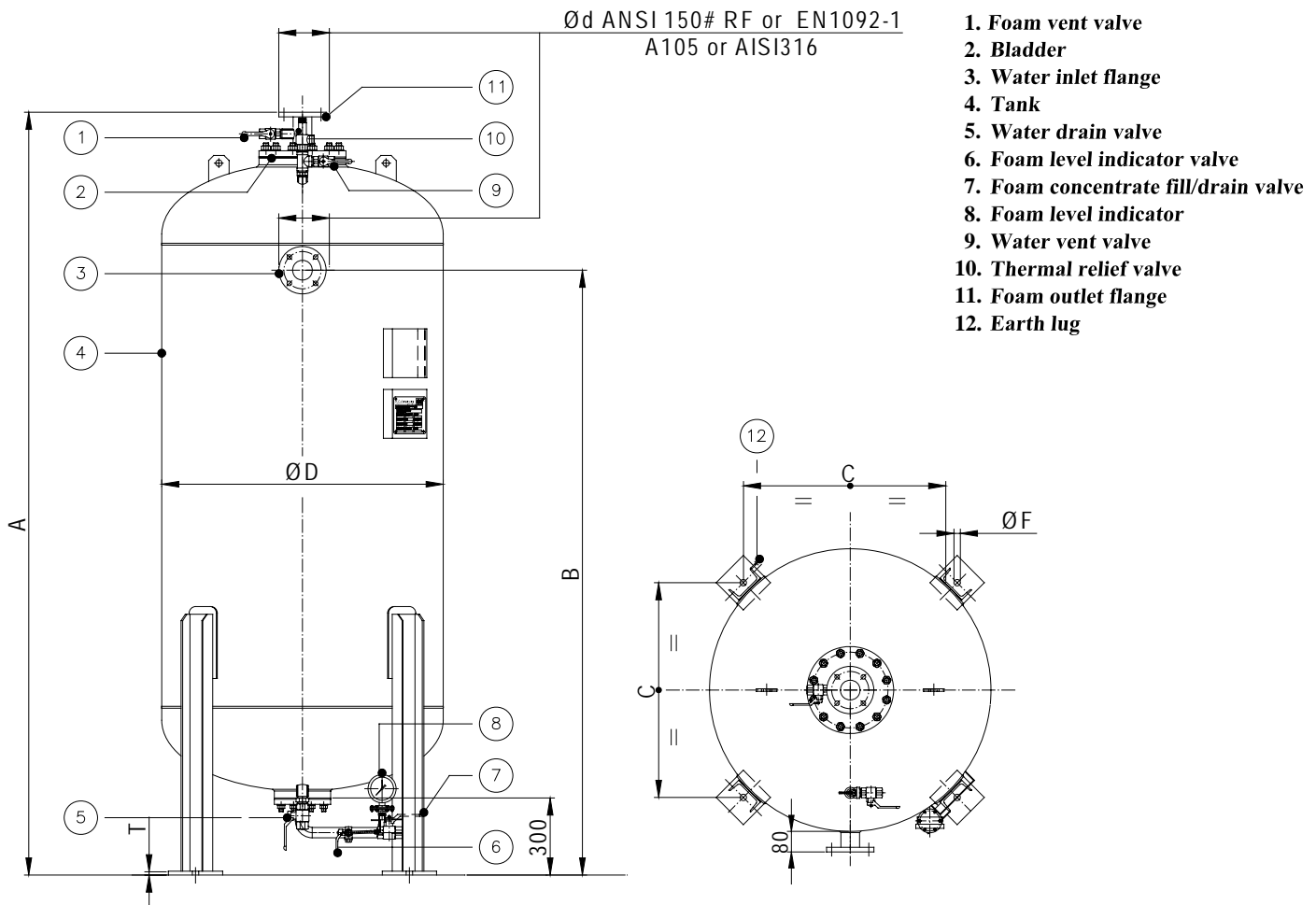

CAPACITY litres	Ød	A mm	B mm	C mm	ØD mm	T mm	ØF mm	WEIGHT (Kg)
1000	2½"	2074	1485	765	1000	15	18	310
1500	2½"	2725	2140	765	1000	15	18	370
2000	2½"	2875	2290	835	1100	15	18	520
2500	3"	2967	2398	920	1200	15	25	800
3000	3"	3141	2544	995	1300	15	25	950
3500	3"	3197	2540	1065	1400	15	25	1080
4000	3"	3325	2654	1100	1450	15	25	1115
4500	3"	3352	2667	1135	1500	15	25	1260
5000	3"	3303	2591	1210	1600	15	25	1365
5500	3"	3553	2641	1210	1600	15	25	1445
6000	3"	3408	2642	1315	1750	15	25	1655
6500	3"	3457	2627	1350	1800	15	25	1715
7000	3"	2162	2278	1500	2000	20	25	2000
7500	3"	3312	2428	1500	2000	20	25	2075
8000	3"	3512	2628	1500	2000	20	25	2180
8500	3"	3662	2778	1500	2000	20	25	2255
9000	3"	3812	2958	1500	2000	20	25	2335
10000	3"	4162	3278	1500	2000	20	25	2520
11000	3"	4462	3578	1500	2000	20	25	2680
12000	3"	4812	3928	1500	2000	20	25	2860

(* The weight shown refers to the ISPEL-VSR version, design pressure 175 psi (12,1 barg)

All the dimensions are in mm

Note: some of the available options may be not covered by the FM approval. Please always make reference to the approval details or ask Viking.



VERTICAL AND HORIZONTAL BLADDER TANKS

Data and specification sheet DS-MXC rev. 0

HORIZONTAL BLADDER TANKS WITHOUT RATIO CONTROLLER

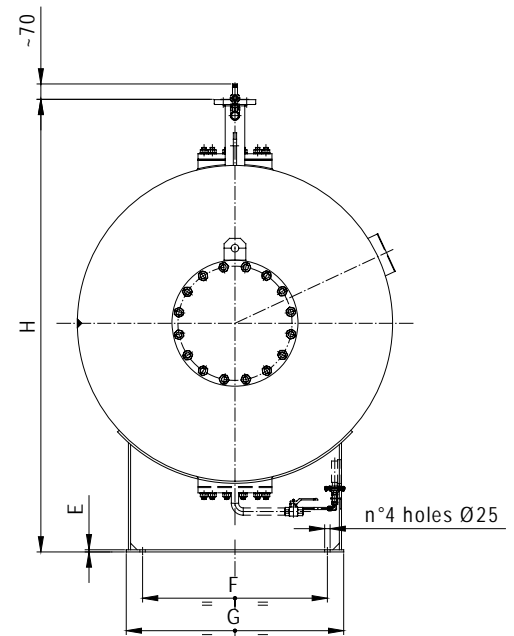
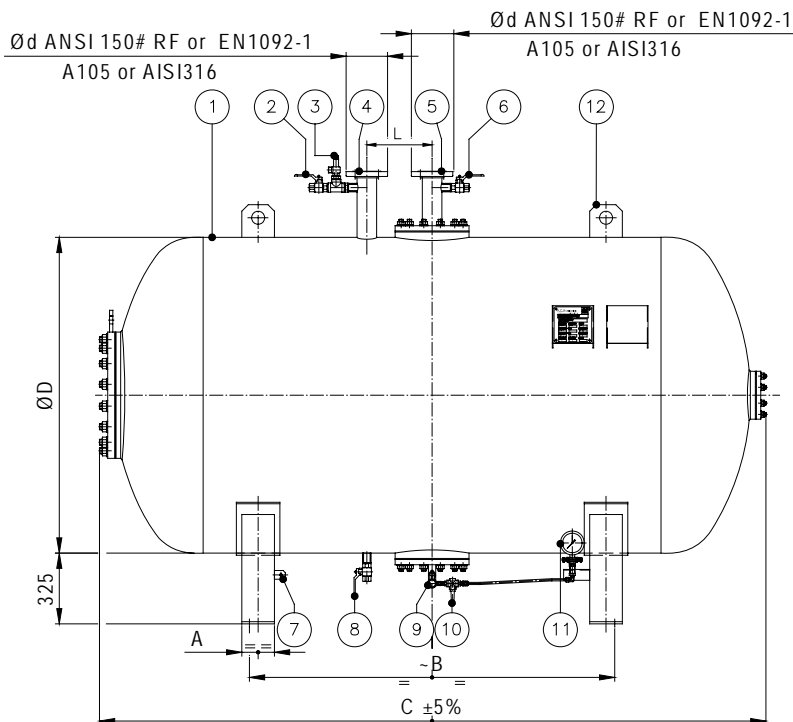

1. Tank
2. Water vent valve
3. Thermal safety valve
4. Water inlet flange
5. Foam outlet flange

6. Foam vent valve
7. Earth lug
8. Water drain valve
9. Foam concentrate fill/drain valve
10. Foam level indicator valve

11. Analog level indicator
12. Lifting lug

CAPACITY litres	A mm	B mm	C mm	ØD mm	F mm	G mm	E mm	H mm	WEIGHT (Kg)
1000	120	820	1765	1000	600	700	8	1525	550
1500	120	1360	2415	1000	600	700	8	1475	630
2000	120	1520	2572	1100	700	800	8	1575	755
2500	150	1560	2705	1200	800	900	8	1675	880
3000	150	1680	2879	1300	800	900	8	1775	1030
3500	150	1680	2952	1400	850	1000	8	1875	1155
4000	150	1380	3078	1450	580	1000	10	1925	1205
4500	150	1780	3107	1500	850	1000	10	1975	1360
5000	200	1680	3061	1600	950	1100	10	2075	1480
5500	200	1910	3311	1600	950	1100	10	2075	1585
6000	200	1680	3160	1750	1050	1200	10	2225	1805
6500	200	1680	3186	1800	1050	1200	10	2275	1865
7000	250	1250	2892	2000	1350	1500	10	2525	2150
7500	250	1400	3042	2000	1350	1500	10	2525	2225
8000	250	1600	3242	2000	1350	1500	10	2475	2325
8500	250	1750	3392	2000	1350	1500	10	2475	2405
9000	250	1900	3542	2000	1350	1500	10	2475	2480
10000	250	2250	3892	2000	1350	1500	10	2475	2660
11000	250	2550	4192	2000	1350	1500	10	2475	2820
12000	250	2900	4542	2000	1350	1500	10	2475	3000
13000	250	3250	4892	2000	1350	1500	10	2475	3240
14000	250	3600	5242	2000	1350	1500	10	2475	3480
15000	250	3950	5592	2000	1350	1500	10	2475	3720

(* The weight shown refers to the ISPEL-VSR version, design pressure 175 psi (12,1 barg)

All the dimensions are in mm

Note: some of the available options may be not covered by the FM approval. Please always make reference to the approval details or ask Viking.



**VERTICAL AND HORIZONTAL
BLADDER TANKS**
Data and specification sheet **DS-MXC rev. 0**

VERTICAL PRE-PIPED BLADDER TANKS

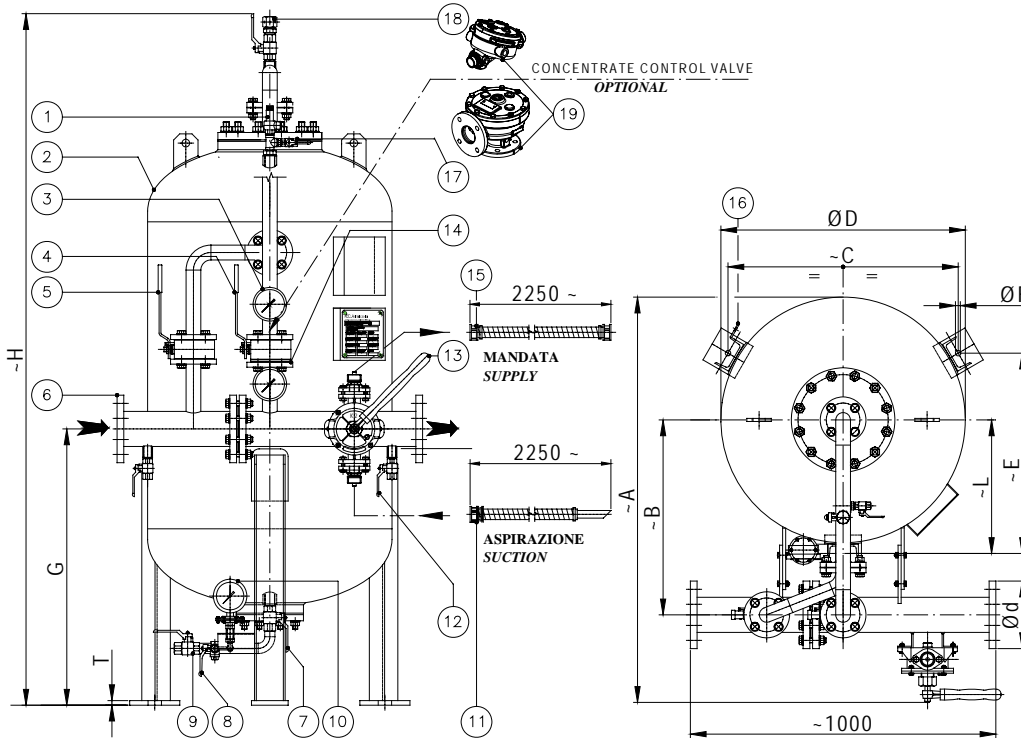

- 1. Thermal relief valve
- 2. Tank
- 3. Tank pressure gauge
- 4. Foam concentrate shut-off valve
- 5. Water shut-off valve
- 6. Ratio controller MIX type
- 7. Water drain valve
- 8. Foam level indicator valve
- 9. Foam concentrate fill/drain valve
- 10. Analog level indicator
- 11. Foam pump suction hose (optional)
- 12. Ratio controller drain valve
- 13. Foam filling pump (optional)
- 14. Foam orifice w/check valve
- 15. Foam pump delivery hose (optional)
- 16. Earth lug
- 17. Water vent valve
- 18. Foam vent valve
- 19. Foam concentrate control valve (optional)

CAPACITY litres	Mixer 2½"			Mixer 3"			Mixer 4"			C mm	ØD mm	E mm	L mm	G mm	H mm	T mm	ØF mm	WEIGHT (Kg) *
	Ød	A mm	B mm	Ød	A mm	B mm	Ød	A mm	B mm									
200	2½"	1085	515	3"	1100	525	4"	1125	535	580.5	600	502.5	335	700	1725	15	18	150
400	2½"	1085	515	3"	1100	525	4"	1125	535	580.5	600	502.5	335	900	2275	15	18	170
600	2½"	1285	615	3"	1300	625	4"	1325	635	755.5	800	654.5	436	900	2155	15	18	200

(*) The table shows the approximate weight of the proportioning system without mixer. The mixer weight must be added to obtain the total weight (see the relevant data page). The weight shown refers to the ISPEL-VSR version, design pressure 175 psi (12,1 bar)
All the dimensions are in mm.



VERTICAL AND HORIZONTAL BLADDER TANKS

Data and specification sheet DS-MXC rev. 0

VERTICAL PRE-PIPED BLADDER TANKS

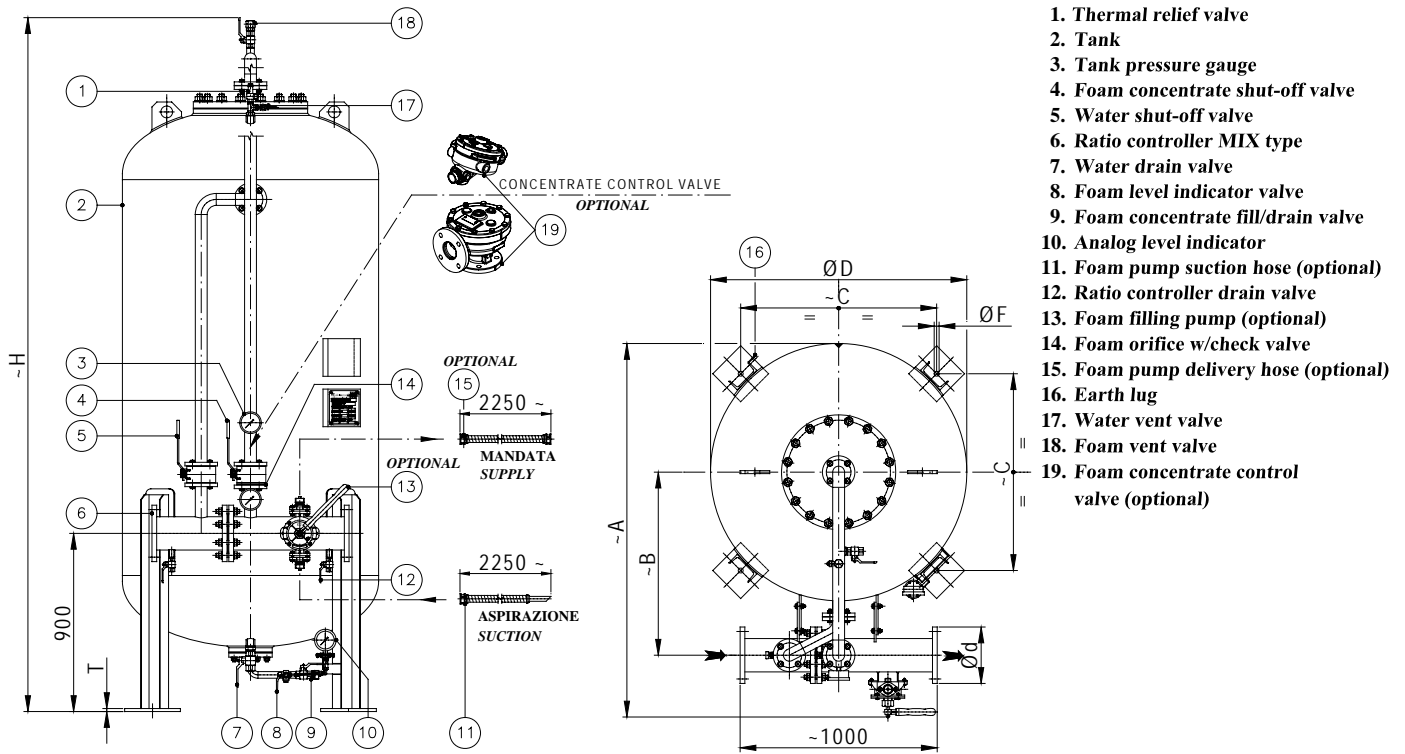

1. Thermal relief valve
2. Tank
3. Tank pressure gauge
4. Foam concentrate shut-off valve
5. Water shut-off valve
6. Ratio controller MIX type
7. Water drain valve
8. Foam level indicator valve
9. Foam concentrate fill/drain valve
10. Analog level indicator
11. Foam pump suction hose (optional)
12. Ratio controller drain valve
13. Foam filling pump (optional)
14. Foam orifice w/check valve
15. Foam pump delivery hose (optional)
16. Earth lug
17. Water vent valve
18. Foam vent valve
19. Foam concentrate control valve (optional)

CAPACITY litres	Mixer 2½"			Mixer 4"			Mixer 6"			Mixer 8"			C mm	ØD mm	H mm	T mm	ØF mm	WEIGHT (Kg) *
	Ød	A mm	B mm	Ød	A mm	B mm	Ød	A mm	B mm	Ød	A mm	B mm						
1000	2½"	1510	735	4"	1535	745	6"	1590	775	8"	1635	795	765	1000	2305	15	18	310
1500	2½"	1510	735	4"	1535	745	6"	1590	775	8"	1635	795	765	1000	2985	15	18	370
2000	2½"	1610	785	4"	1635	795	6"	1690	825	8"	1735	845	835	1100	3245	15	18	520
2500	2½"	1710	835	4"	1735	845	6"	1790	875	8"	1835	895	920	1200	3375	15	25	800
3000	2½"	1810	885	4"	1835	895	6"	1890	925	8"	1935	945	995	1300	3550	15	25	950
3500	2½"	1910	935	4"	1935	945	6"	1990	975	8"	2035	995	1065	1400	3615	15	25	1080
4000	2½"	1960	960	4"	1985	970	6"	2040	1000	8"	2090	1025	1100	1450	3745	15	25	1115
4500	2½"	2010	985	4"	2035	995	6"	2090	1025	8"	2140	1050	1135	1500	3755	15	25	1260
5000	2½"	2110	1035	4"	2135	1045	6"	2190	1075	8"	2245	1105	1210	1600	3725	15	25	1365
5500	2½"	2110	1035	4"	2135	1045	6"	2190	1075	8"	2245	1105	1210	1600	3975	15	25	1445
6000	2½"	2260	1110	4"	2285	1120	6"	2340	1150	8"	2395	1180	1315	1750	3805	15	25	1655
6500	2½"	2310	1135	4"	2335	1145	6"	2395	1180	8"	2445	1205	1350	1800	3835	15	25	1715
7000	2½"	2510	1235	4"	2535	1245	6"	2595	1280	8"	2645	1305	1500	2000	3545	20	25	2000
7500	2½"	2510	1235	4"	2535	1245	6"	2595	1280	8"	2645	1305	1500	2000	3695	20	25	2075
8000	2½"	2510	1235	4"	2535	1245	6"	2595	1280	8"	2645	1305	1500	2000	3895	20	25	2180
8500	2½"	2510	1235	4"	2535	1245	6"	2595	1280	8"	2645	1305	1500	2000	4045	20	25	2255
9000	2½"	2510	1235	4"	2535	1245	6"	2595	1280	8"	2645	1305	1500	2000	4195	20	25	2335
10000	2½"	2510	1235	4"	2535	1245	6"	2595	1280	8"	2645	1305	1500	2000	4545	20	25	2520
11000	2½"	2510	1235	4"	2535	1245	6"	2595	1280	8"	2645	1305	1500	2000	4845	20	25	2680
12000	2½"	2510	1235	4"	2535	1245	6"	2595	1280	8"	2645	1305	1500	2000	5195	20	25	2860

(*) The table shows the approximate weight of the proportioning system without mixer. The mixer weight must be added to obtain the total weight (see the relevant data page). The weight shown refers to the ISPEL-VSR version, design pressure 175 psi (12,1 bar)
All the dimensions are in mm.

VIKING®

VERTICAL AND HORIZONTAL BLADDER TANKS

Data and specification sheet DS-MXC rev. 0

HORIZONTAL PRE-PIPED BLADDER TANKS

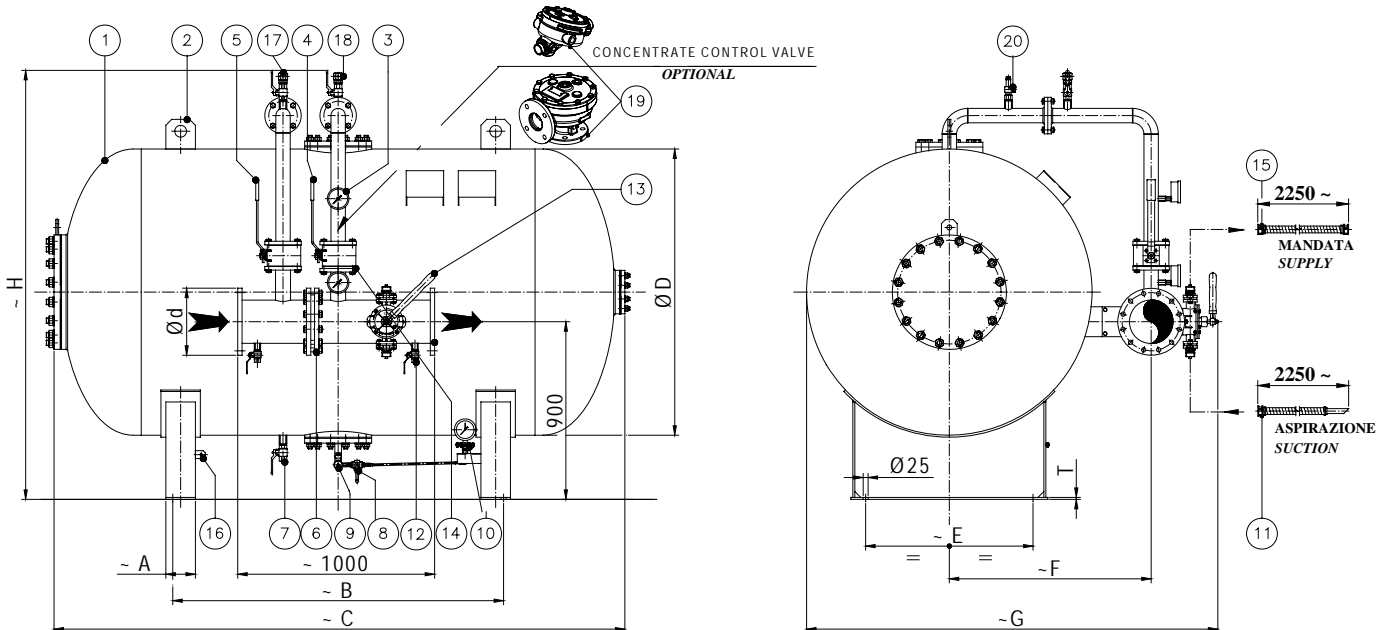

- | | | |
|------------------------------------|--------------------------------------|--|
| 1. Tank | 6. Ratio controller MIX type | 11. Foam pump suction hose (optional) |
| 2. Lifting lug | 7. Water drain valve | 12. Ratio controller drain valve |
| 3. Tank pressure gauge | 8. Foam level indicator valve | 13. Foam filling pump (optional) |
| 4. Foam concentrate shut-off valve | 9. Foam concentrate fill/drain valve | 14. Foam orifice w/check valve |
| 5. Water shut-off valve | 10. Analog level indicator | 15. Foam pump delivery hose (optional) |
| | | 16. Earth lug |
| | | 17. Water vent valve |
| | | 18. Foam vent valve |
| | | 19. Foam control valve (optional) |
| | | 20. Thermal relief valve |

CAPACITY litres	Mixer 2½"			Mixer 4"			Mixer 6"			Mixer 8"			T mm	H mm	WEIGHT (Kg) *					
	A mm	B mm	C mm	Ø D mm	E mm	Ød mm	F mm	G mm	Ød mm	F mm	G mm	Ød mm				F mm	G mm			
1000	120	820	1765	1000	600	2½"	735	1510	4"	745	1535	6"	775	1590	8"	795	1635	8	1755	550
1500	120	1360	2415	1000	600	2½"	735	1510	4"	745	1535	6"	775	1590	8"	795	1635	8	1755	630
2000	120	1520	2572	1100	700	2½"	785	1610	4"	795	1635	6"	825	1690	8"	845	1735	8	1855	755
2500	150	1560	2705	1200	800	2½"	835	1710	4"	845	1735	6"	875	1790	8"	895	1835	8	1955	880
3000	150	1680	2879	1300	800	2½"	885	1810	4"	895	1835	6"	925	1890	8"	945	1935	8	2055	1030
3500	150	1680	2952	1400	850	2½"	935	1910	4"	945	1935	6"	975	1990	8"	995	2035	8	2155	1155
4000	150	1680	3078	1450	850	2½"	960	1960	4"	970	1985	6"	1000	2040	8"	1025	2090	10	2205	1205
4500	150	1780	3107	1500	850	2½"	985	2010	4"	995	2035	6"	1025	2090	8"	1050	2140	10	2255	1360
5000	200	1680	3061	1600	950	2½"	1035	2110	4"	1045	2135	6"	1075	2190	8"	1105	2245	10	2355	1480
5500	200	1910	3311	1600	950	2½"	1035	2110	4"	1045	2135	6"	1075	2190	8"	1105	2245	10	2355	1585
6000	200	1680	3160	1750	1050	2½"	1110	2260	4"	1120	2285	6"	1150	2340	8"	1180	2395	10	2505	1805
6500	200	1680	3186	1800	1050	2½"	1135	2310	4"	1145	2335	6"	1180	2395	8"	1205	2445	10	2555	1865
7000	250	1250	2892	2000	1350	2½"	1235	2510	4"	1245	2535	6"	1280	2595	8"	1305	2645	10	2755	2150
7500	250	1400	3042	2000	1350	2½"	1235	2510	4"	1245	2535	6"	1280	2595	8"	1305	2645	10	2755	2225
8000	250	1600	3242	2000	1350	2½"	1235	2510	4"	1245	2535	6"	1280	2595	8"	1305	2645	10	2755	2325
8500	250	1750	3392	2000	1350	2½"	1235	2510	4"	1245	2535	6"	1280	2595	8"	1305	2645	10	2755	2405
9000	250	1900	3542	2000	1350	2½"	1235	2510	4"	1245	2535	6"	1280	2595	8"	1305	2645	10	2755	2480
10000	250	2250	3892	2000	1350	2½"	1235	2510	4"	1245	2535	6"	1280	2595	8"	1305	2645	10	2755	2660
11000	250	2550	4192	2000	1350	2½"	1235	2510	4"	1245	2535	6"	1280	2595	8"	1305	2645	10	2755	2820
12000	250	2900	4542	2000	1350	2½"	1235	2510	4"	1245	2535	6"	1280	2595	8"	1305	2645	10	2755	3000
13000	250	3250	4892	2000	1350	2½"	1235	2510	4"	1245	2535	6"	1280	2595	8"	1305	2645	10	2755	3240
14000	250	3600	5242	2000	1350	2½"	1235	2510	4"	1245	2535	6"	1280	2595	8"	1305	2645	10	2755	3480
15000	250	3950	5592	2000	1350	2½"	1235	2510	4"	1245	2535	6"	1280	2595	8"	1305	2645	10	2755	3720

(*) The table shows the approximate weight of the proportioning system without mixer. The mixer weight must be added to obtain the total weight (see the relevant data page). The weight shown refers to the ISPEL-VSR version, design pressure 175 psi (12,1 bar)

All the dimensions are in mm.



VERTICAL AND HORIZONTAL BLADDER TANKS

Data and specification sheet DS-MXC rev. 0

VERTICAL PRE-PIPED BLADDER TANKS WITH WIDE RANGE RATIO CONTROLLER

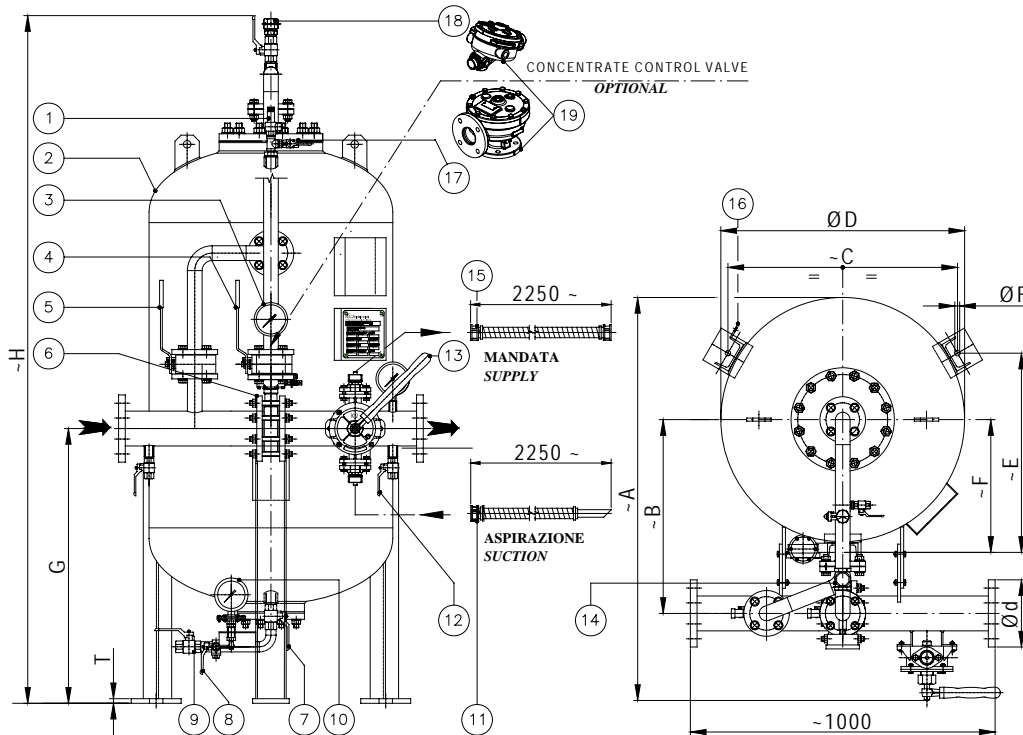

1. Thermal relief valve
2. Tank
3. Tank pressure gauge
4. Foam concentrate shut-off valve
5. Water shut-off valve
6. Wide Range ratio controller KWR
7. Water drain valve
8. Foam level indicator valve
9. Foam concentrate fill/drain valve
10. Analog level indicator
11. Foam pump suction hose (optional)
12. Ratio controller drain valve
13. Foam filling pump (optional)
14. Check valve
15. Foam pump delivery hose (optional)
16. Earth lug
17. Water vent valve
18. Foam vent valve
19. Foam concentrate control valve (optional)

CAPACITY litres	KWR 100/50			KWR 150/50			KWR 200/80			C mm	ØD mm	E mm	F mm	G mm	H mm	T mm	ØF mm	WEIGHT (Kg) *
	Ød	A mm	B mm	Ød	A mm	B mm	Ød	A mm	B mm									
200	4"	1125	535	6"	1180	565	8"	1225	585	581	600	503	335	700	1725	15	18	150
400	4"	1125	535	6"	1180	565	8"	1225	585	581	600	503	335	900	2275	15	18	170
600	4"	1325	635	6"	1380	665	8"	1425	685	756	800	655	436	900	2155	15	18	200

(*) The table shows the approximate weight of the proportioning system without mixer. The mixer weight must be added to obtain the total weight (see the relevant data page). The weight shown refers to the ISPEL-VSR version, design pressure 175 psi (12,1 bar)
All the dimensions are in mm.



**VERTICAL AND HORIZONTAL
BLADDER TANKS**
Data and specification sheet **DS-MXC rev. 0**

VERTICAL PRE-PIPED BLADDER TANKS WITH WIDE RANGE RATIO CONTROLLER

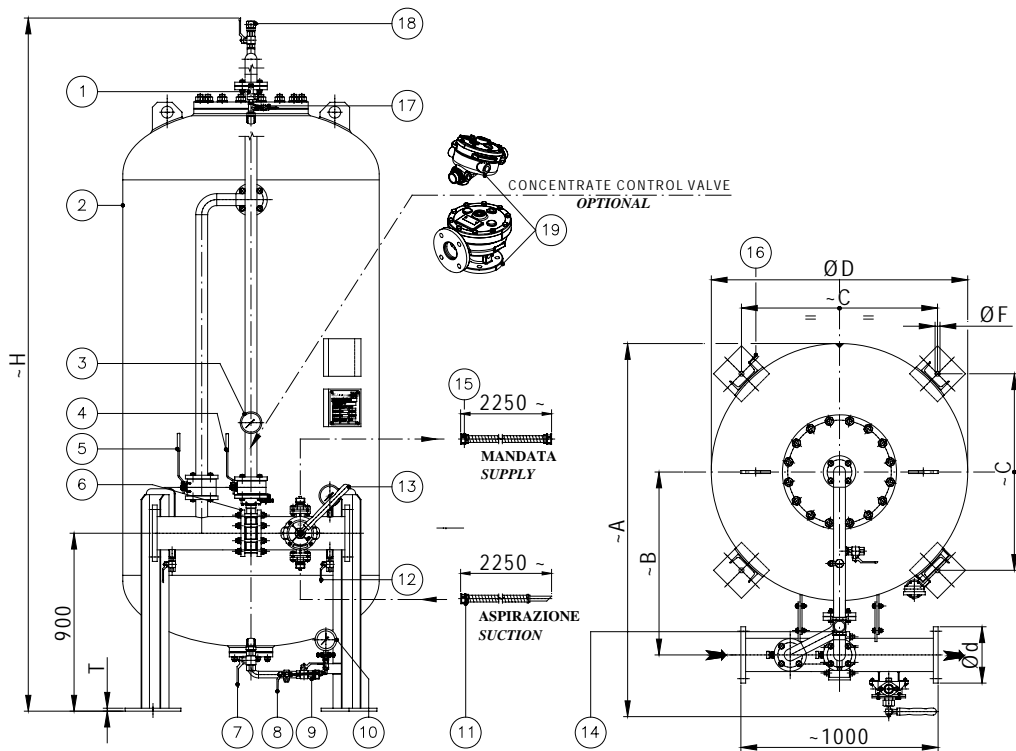

1. Thermal relief valve
2. Tank
3. Tank pressure gauge
4. Foam concentrate shut-off valve
5. Water shut-off valve
6. Wide Range ratio controller KWR
7. Water drain valve
8. Foam level indicator valve
9. Foam concentrate fill/drain valve
10. Analog level indicator
11. Foam pump suction hose (optional)
12. Ratio controller drain valve
13. Foam filling pump (optional)
14. Check valve
15. Foam pump delivery hose (optional)
16. Earth lug
17. Water vent valve
18. Foam vent valve
19. Foam concentrate control valve (optional)

CAPACITY litres	KWR 100/50			KWR 150/50			KWR 200/80			KWR 250/80			ØD mm	H mm	T mm	ØF mm	WEIGHT (Kg) *	
	Ød	A mm	B mm	Ød	A mm	B mm	Ød	A mm	B mm	Ød	A mm	B mm						C mm
1000	4"	1535	745	6"	1590	775	8"	1635	795	10"	1690	822	765	1000	2305	15	18	310
1500	4"	1535	745	6"	1590	775	8"	1635	795	10"	1690	822	765	1000	2985	15	18	370
2000	4"	1635	795	6"	1690	825	8"	1735	845	10"	1790	872	835	1100	3245	15	18	520
2500	4"	1735	845	6"	1790	875	8"	1835	895	10"	1890	922	920	1200	3375	20	25	800
3000	4"	1835	895	6"	1890	925	8"	1935	945	10"	1990	975	995	1300	3550	20	25	950
3500	4"	1935	945	6"	1990	975	8"	2035	995	10"	2090	1022	1065	1400	3615	20	25	1080
4000	4"	1985	970	6"	2040	1000	8"	2090	1025	10"	2140	1047	1100	1450	3745	20	25	1115
4500	4"	2035	995	6"	2090	1025	8"	2140	1050	10"	2190	1072	1135	1500	3755	20	25	1260
5000	4"	2135	1045	6"	2190	1075	8"	2245	1105	10"	2290	1122	1210	1600	3725	20	25	1365
5500	4"	2135	1045	6"	2190	1075	8"	2245	1105	10"	2290	1122	1210	1600	3975	20	25	1445
6000	4"	2285	1120	6"	2340	1150	8"	2395	1180	10"	2440	1197	1315	1750	3805	20	25	1655
6500	4"	2335	1145	6"	2395	1180	8"	2445	1205	10"	2490	1223	1350	1800	3835	20	25	1715
7000	4"	2535	1145	6"	2595	1280	8"	2645	1305	10"	2690	1332	1500	2000	3545	20	25	2000
7500	4"	2535	1245	6"	2595	1280	8"	2645	1305	10"	2690	1332	1500	2000	3695	20	25	2075
8000	4"	2535	1245	6"	2595	1280	8"	2645	1305	10"	2690	1332	1500	2000	3895	20	25	2180
8500	4"	2535	1245	6"	2595	1280	8"	2645	1305	10"	2690	1332	1500	2000	4045	20	25	2255
9000	4"	2535	1245	6"	2595	1280	8"	2645	1305	10"	2690	1332	1500	2000	4195	20	25	2335
10000	4"	2535	1245	6"	2595	1280	8"	2645	1305	10"	2690	1332	1500	2000	4545	20	25	2520
11000	4"	2535	1245	6"	2595	1280	8"	2645	1305	10"	2690	1332	1500	2000	4845	20	25	2680
12000	4"	2535	1245	6"	2595	1280	8"	2645	1305	10"	2690	1332	1500	2000	5195	20	25	2860

(* The table shows the approximate weight of the proportioning system without mixer. The mixer weight must be added to obtain the total weight (see the relevant data page). The weight shown refers to the ISPEL-VSR version, design pressure 175 psi (12,1 bar)
All the dimensions are in mm.



VERTICAL AND HORIZONTAL BLADDER TANKS

Data and specification sheet

DS-MXC rev. 0

HORIZONTAL PRE-PIPED BLADDER TANKS WITH WIDE RANGE RATIO CONTROLLER

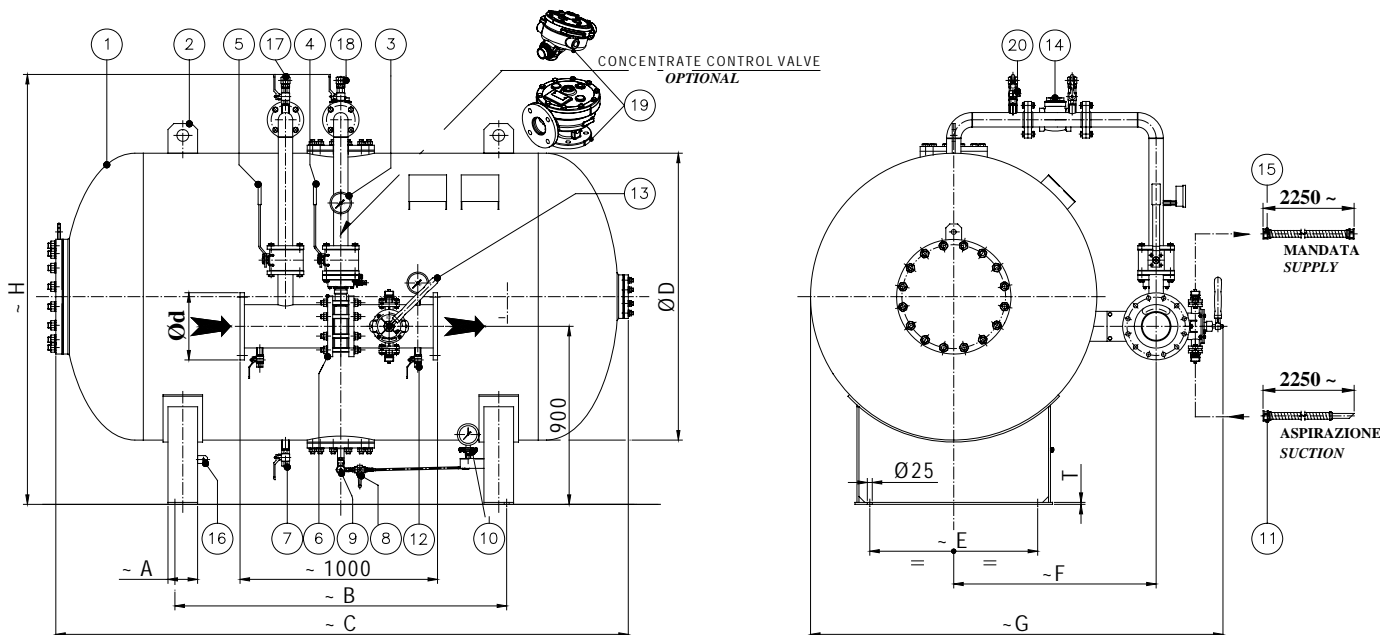

- 1. Tank
- 2. Lifting lug
- 3. Tank pressure gauge
- 4. Foam concentrate shut-off valve
- 5. Water shut-off valve
- 6. Ratio controller KWR type
- 7. Water drain valve
- 8. Foam level indicator valve
- 9. Foam concentrate fill/drain valve
- 10. Analog level indicator
- 11. Foam pump suction hose (optional)
- 12. Ratio controller drain valve
- 13. Foam filling pump (optional)
- 14. Foam check valve
- 15. Foam pump delivery hose (optional)
- 16. Earth lug
- 17. Water vent valve
- 18. Foam vent valve
- 19. Foam control valve (optional)
- 20. Thermal relief valve

CAPACITY litres	KWR 100/50				KWR 150/50				KWR 200/80				KWR 250/80				T mm	H mm	WEIGHT (Kg) *	
	A mm	B mm	C mm	Ø D mm	E mm	Ød	F mm	G mm	Ød	F mm	G mm	Ød	F mm	G mm	Ød	F mm				G mm
1000	120	820	1765	1000	600	4"	745	1535	6"	775	1590	8"	795	1635	10"	822	1690	8	1755	550
1500	120	1360	2415	1000	600	4"	745	1535	6"	775	1590	8"	795	1635	10"	822	1690	8	1755	630
2000	120	1520	2572	1100	700	4"	795	1635	6"	825	1690	8"	845	1735	10"	872	1790	8	1855	755
2500	150	1560	2705	1200	800	4"	845	1735	6"	875	1790	8"	895	1835	10"	922	1890	8	1955	880
3000	150	1680	2879	1300	800	4"	895	1835	6"	925	1890	8"	945	1935	10"	972	1990	8	2055	1030
3500	150	1680	2952	1400	850	4"	945	1935	6"	975	1990	8"	995	2035	10"	1022	2090	8	2155	1155
4000	150	1680	3078	1450	850	4"	970	1985	6"	1000	2040	8"	1025	2090	10"	1047	2140	10	2205	1205
4500	150	1780	3107	1500	850	4"	995	2035	6"	1025	2090	8"	1050	2140	10"	1072	2190	10	2255	1360
5000	200	1680	3061	1600	950	4"	1045	2135	6"	1075	2190	8"	1105	2245	10"	1122	2290	10	2355	1480
5500	200	1910	3311	1600	950	4"	1045	2135	6"	1075	2190	8"	1105	2245	10"	1122	2290	10	2355	1585
6000	200	1680	3160	1750	1050	4"	1120	2285	6"	1150	2340	8"	1180	2395	10"	1197	2440	10	2505	1805
6500	200	1680	3186	1800	1050	4"	1145	2335	6"	1180	2395	8"	1205	2445	10"	1223	2490	10	2555	1865
7000	250	1250	2892	2000	1350	4"	1245	2535	6"	1280	2595	8"	1305	2645	10"	1332	2690	10	2755	2150
7500	250	1400	3042	2000	1350	4"	1245	2535	6"	1280	2595	8"	1305	2645	10"	1332	2690	10	2755	2225
8000	250	1600	3242	2000	1350	4"	1245	2535	6"	1280	2595	8"	1305	2645	10"	1332	2690	10	2755	2325
8500	250	1750	3392	2000	1350	4"	1245	2535	6"	1280	2595	8"	1305	2645	10"	1332	2690	10	2755	2405
9000	250	1900	3542	2000	1350	4"	1245	2535	6"	1280	2595	8"	1305	2645	10"	1332	2690	10	2755	2480
10000	250	2250	3892	2000	1350	4"	1245	2535	6"	1280	2595	8"	1305	2645	10"	1332	2690	10	2755	2660
11000	250	2550	4192	2000	1350	4"	1245	2535	6"	1280	2595	8"	1305	2645	10"	1332	2690	10	2755	2820
12000	250	2900	4542	2000	1350	4"	1245	2535	6"	1280	2595	8"	1305	2645	10"	1332	2690	10	2755	3000
13000	250	3250	4892	2000	1350	4"	1245	2535	6"	1280	2595	8"	1305	2645	10"	1332	2690	10	2755	3240
14000	250	3600	5242	2000	1350	4"	1245	2535	6"	1280	2595	8"	1305	2645	10"	1332	2690	10	2755	3480
15000	250	3950	5592	2000	1350	4"	1245	2535	6"	1280	2595	8"	1305	2645	10"	1332	2690	10	2755	3720

(*) The table shows the approximate weight of the proportioning system without mixer. The mixer weight must be added to obtain the total weight (see the relevant data page). The weight shown refers to the ISPEL-VSR version, design pressure 175 psi (12,1 bar)

All the dimensions are in mm.